



High Pressure. Cleaner Solutions.

Technical Data Sheet



- Proven Harben® reliability
- Fully pivoting hose reel
- Can operate with van doors closed
- Compact design
- Sewers up to 300mm diameter

Model	Flowplant Harben® Drainmaster
Pressure & Flow	3500 psi @ 16 gpm 4000 psi @ 12 gpm 5000 psi @ 9 gpm 6000 psi @ 7 gpm
Pump	Harben® 'P' type radial piston diaphragm
Engine	Kubota 48 hp water cooled diesel by heat exchanger
Water Tank	Single – 90 gallons (390 litres) Twin – 180 gallons (780 litres)
Frame	Lightweight folded steel shot blasted and powder coated
Swing Out Hose Reel	Fully pivoting variable-speed hydraulic-rewind hose reel with 100m high-pressure hose capacity, 90m hose included
Dimensions	1500 mm Long X1425 mm Wide X 1470mm High
Weight	Dry weight: From 810 kg
Build Options	Full radio remote control including hose reel Jump Jet™ kit, Close van door option

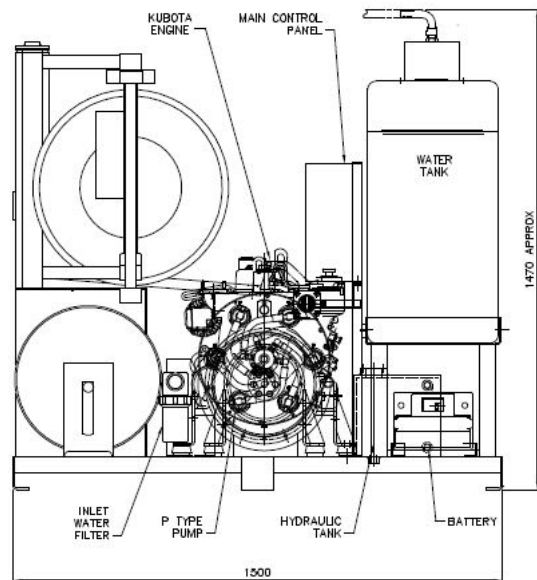
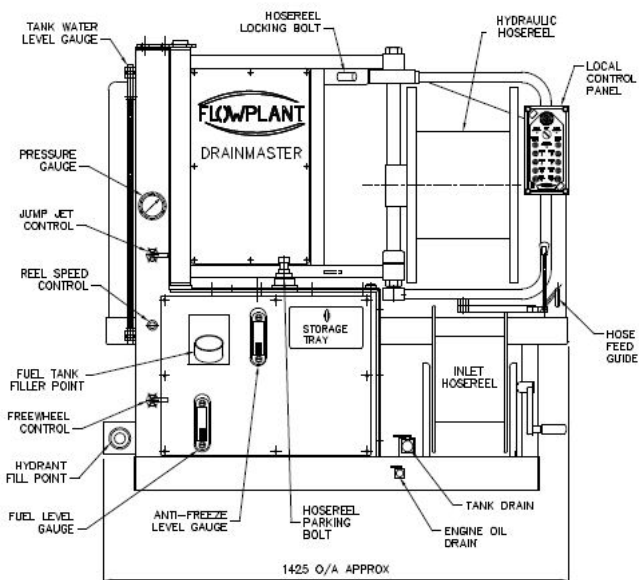

e: sales@flowplant.com
t: +44 (0)1722 325424
f: +44 (0)1722 411329

Gemini House, Brunel Road,
Churchfields Industrial Estate,
Salisbury, Wiltshire. SP2 7PU
United Kingdom