



High Pressure. Cleaner Solutions.

Technical Data Sheet



- Standard kit included
- Hydraulic reel option
- Drains up to 225mm diameter

Model	Mini Econopack
Pressure & Flow	3000 psi @ 10 gpm
Pump	Speck triplex plunger pump
Engine	Lombardini 30 hp water cooled diesel
Water Tank	Single – 60 gallons (260 litres)
Frame	Lightweight folded steel shot blasted and powder coated
Hose Reel	Variable-speed hydraulic-rewind hose reel with 100m high-pressure hose capacity, 90m hose included
Dimensions	1525mm Long X 1105mm Wide X 1385 mm High
Weight	Dry weight: From 480kg
Build Options	Hydraulic hose reel, Hard Wire remote control

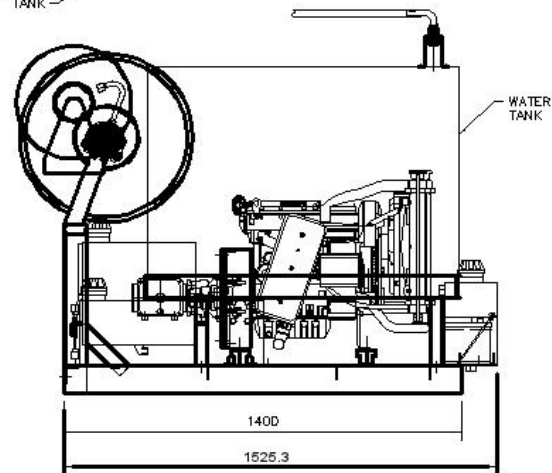
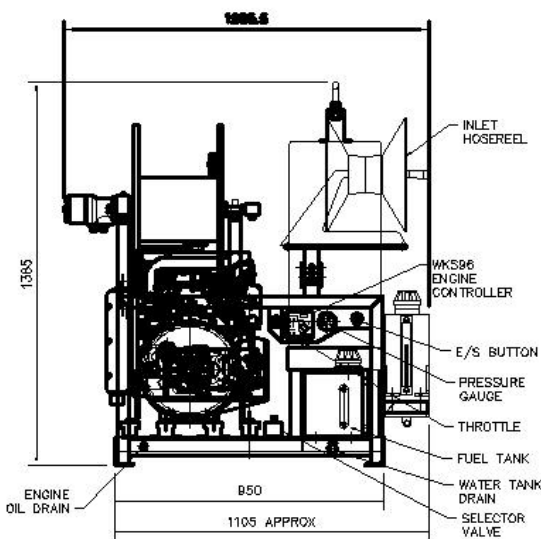
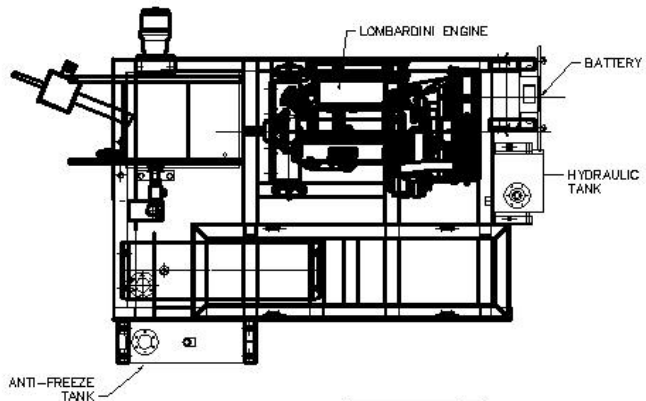

e: sales@flowplant.com
 t: +44 (0)1722 325424
 f: +44 (0)1722 411329

Gemini House, Brunel Road,
 Churchfields Industrial Estate,
 Salisbury, Wiltshire. SP2 7PU
 United Kingdom