



## High Pressure. Cleaner Solutions.

### Technical Data Sheet



Model	Century trailer unit
Engine	Iveco Ford 55, 75 & 110 kW
Pump	Harben Century type radial piston diaphragm
Water Tank	Twin - 200 gallons (908 litres).
Hose Reel	Variable-speed hydraulic-rewind hose reel with 100m high-pressure hose capacity, hose included.
Dimensions	3230 mm Long X 1825 mm Wide X 1950 mm High.
Weight	Dry weight: 1460kg, Wet weight: 2500kg
Options	Perkins Engine 60, 75 & 100kW

- Harben Century pump
- Industrial high-pressure cleaning
- Variable speed hydraulic rewind hose reel

Performance options	Pressure	Flow
422.519	700 bar	52 l/min
425.019	700 bar	66 l/min
427.519	470 bar	80 l/min
822.519	700 bar	105 l/min
825.019	700 bar	128 l/min
827.519	470 bar	155 l/min

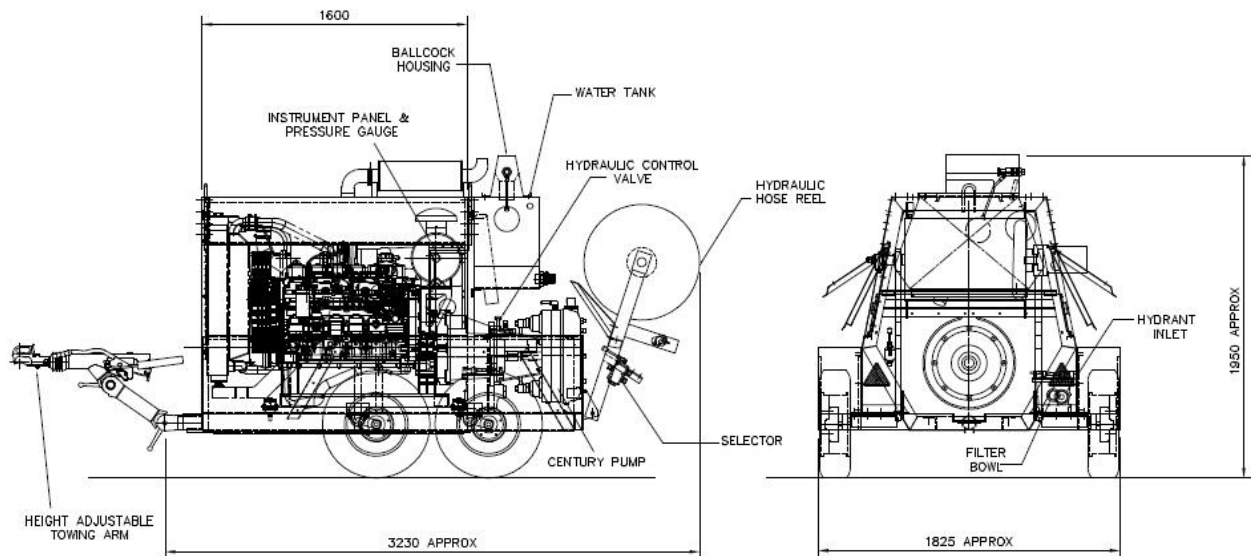

e: [sales@flowplant.com](mailto:sales@flowplant.com)  
 t: +44 (0)1722 325424  
 f: +44 (0)1722 411329

Gemini House, Brunel Road,  
 Churchfields Industrial Estate,  
 Salisbury, Wiltshire. SP2 7PU  
 United Kingdom