



High Pressure. Cleaner Solutions.

Technical Data Sheet



- **Exceptional value for money**
- **Ideal choice for back up machine**
- **Fits all popular vans**
- **Drains up to 150mm**

Model	Compack 3008
Pressure & Flow	3000 psi @ 8 gpm
Pump	Hawk triplex plunger pump.
Engine	20hp petrol
Water Tank	Single – 70 gallons (320 litres)
Frame	Lightweight box section steel
Hose reel	Electrically powered rewind with 60m high pressure hose capacity
Dimensions	1250mm Long X 1050mm Wide X 850mm High
Weight	Dry weight: From 215kg
Build Options	Carrying trailer, Hard Wire remote control, inlet hose reel

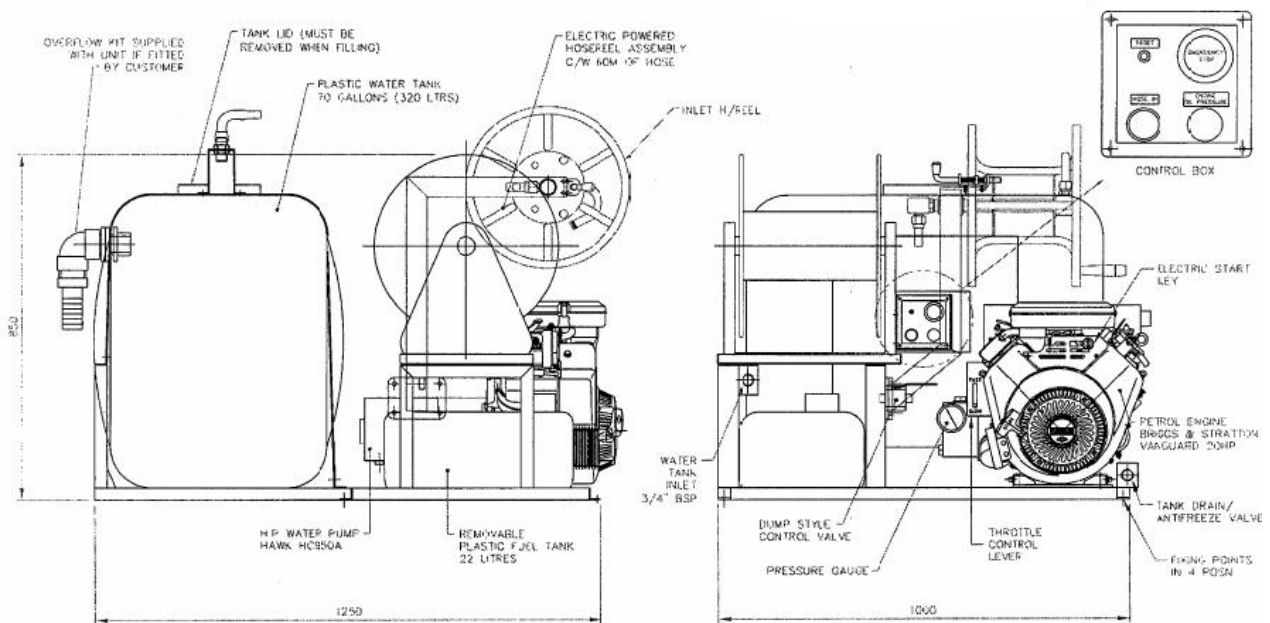

e: sales@flowplant.com
 t: +44 (0)1722 325424
 f: +44 (0)1722 411329

Gemini House, Brunel Road,
 Churchfields Industrial Estate,
 Salisbury, Wiltshire. SP2 7PU
 United Kingdom