



High Pressure. Cleaner Solutions.

Technical Data Sheet



- Ideal for housing associations, municipalities and plumbers
- Proven Harben® reliability
- Clean small bore drains up to 200mm

Model	DTM trailer unit
Pressure & Flow	5000 psi @ 5 gpm 4000 psi @ 6 gpm 3000 psi @ 8 gpm
Pump	Harben® 'P type' radial piston diaphragm
Engine	Yanmar 22 hp water cooled diesel engine
Water Tank	Twin - capacity approximately 50 gals. (227 litres).
Frame	Box section steel shot blasted and powder coated
Hose Reel	Manually wound hose reel with 90m high pressure hose capacity, 60m hose included
Dimensions	2580mm Long X 1385mm Wide X 1340mm High.
Weight	Dry weight: From 520kg.
Build Options	Hard wire remote control, Jump Jet® Kit, Inlet hose reel

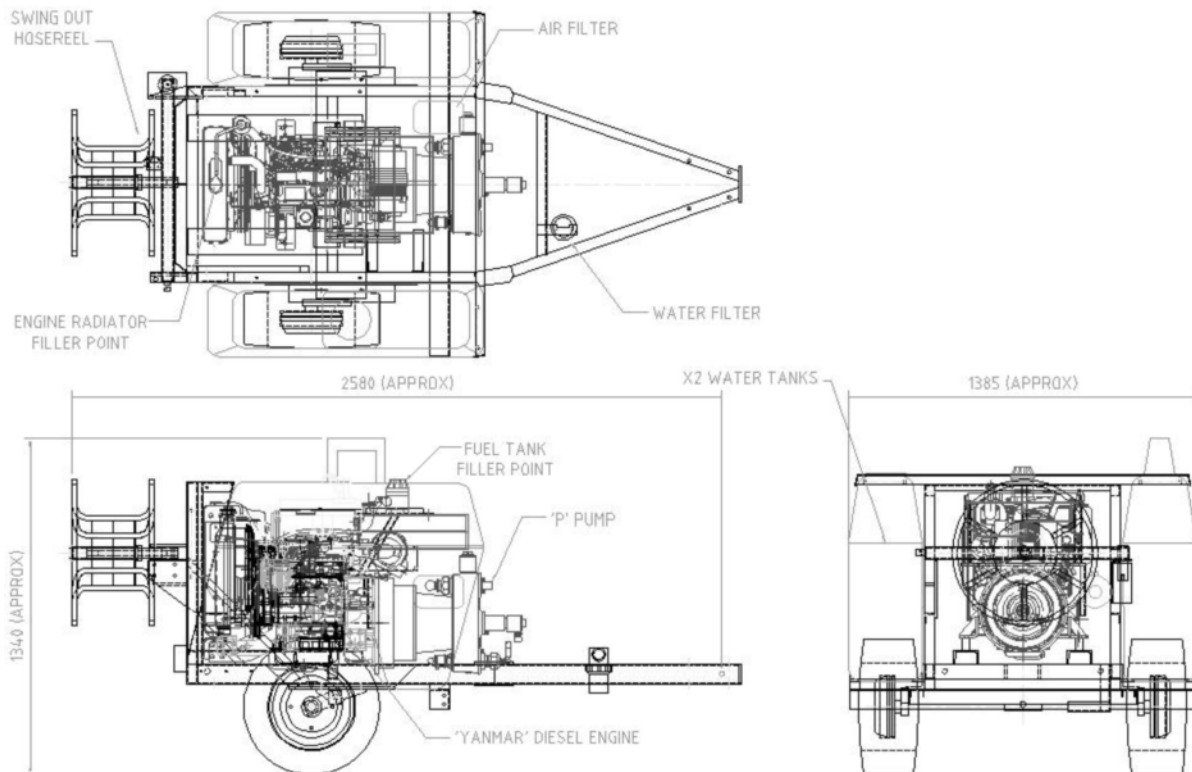

e: sales@flowplant.com
 t: +44 (0)1722 325424
 f: +44 (0)1722 411329

Gemini House, Brunel Road,
 Churchfields Industrial Estate,
 Salisbury, Wiltshire. SP2 7PU
 United Kingdom