



High Pressure. Cleaner Solutions.

Technical Data Sheet



New

- Proven Harben® reliability
- 200 gallons (910 litres) water tanks for longer working
- Hydraulic hose reel holds 150m of 5/8" high-pressure hose
- Sewers up to 600mm diameter

Model	DTQ trailer unit
Pressure and Flow	4000 psi @ 20 gpm
Pump	Harben® Hi 'Q' type radial piston diaphragm.
Engine	Perkins 80 hp water cooled diesel
Water Tank	Four interconnected water storage tanks with a total capacity of 910 litres (200 gallons)
Frame	Box section steel shot blasted and powder coated mounted on separate axles and tow bar
Hose Reel	Variable-speed hydraulic-rewind hose reel with 150m x 5/8" high-pressure hose capacity, hose included.
Dimensions	5120 mm Long max X 1890mm Wide X 1550 mm High.
Weight	Dry weight: From 2000kg dry, 2910kg full
Build Options	Jump Jet® Kit, Inlet hose reel

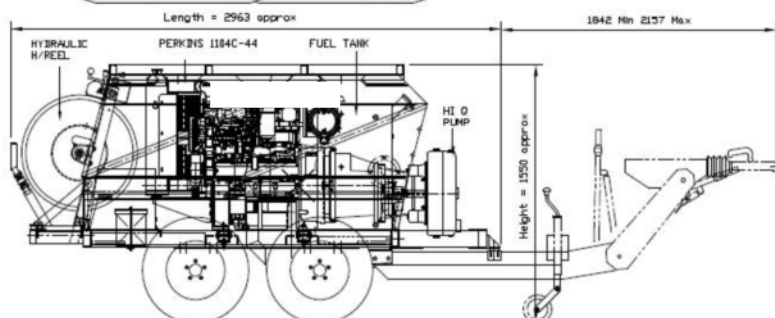
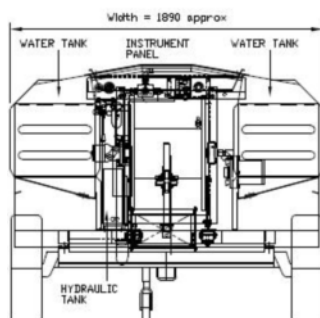
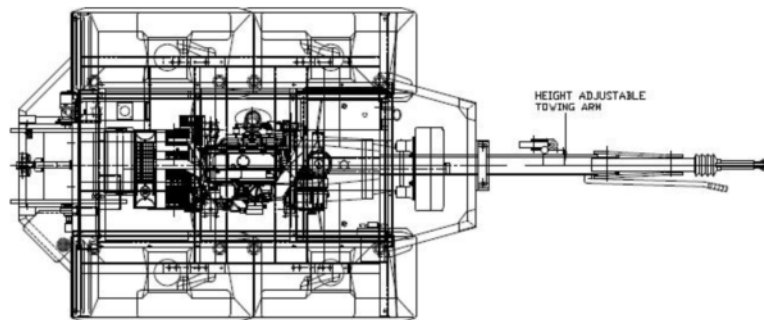

e: sales@flowplant.com
 t: +44 (0)1722 325424
 f: +44 (0)1722 411329

Gemini House, Brunel Road,
 Churchfields Industrial Estate,
 Salisbury, Wiltshire. SP2 7PU
 United Kingdom