



## High Pressure. Cleaner Solutions.

### Technical Data Sheet



- Ideal for smaller drains to 100mm
- Trolley mounted versatility
- Perfect for inaccessible areas
- Complete with drain jets

Model	JetCart 3003
Pressure & Flow	3000 psi @ 3.3 gpm
Pump	Hawk Triplex Plunger Pump.
Engine	Honda 9 hp petrol engine
Water Tank	11 litre water break tank with ball valve control
Frame	Lightweight tubular steel shot blasted and powder coated
Hose Reel	Manually wound detachable hose reel with capacity of 100ft high pressure hose
Dimensions	950mm Long x 650mm Wide x 1050mm High.
Weight	86kg (inc. hose reel), 69Kg (excl. hose reel).
Build options	Additional 270 litre water tank

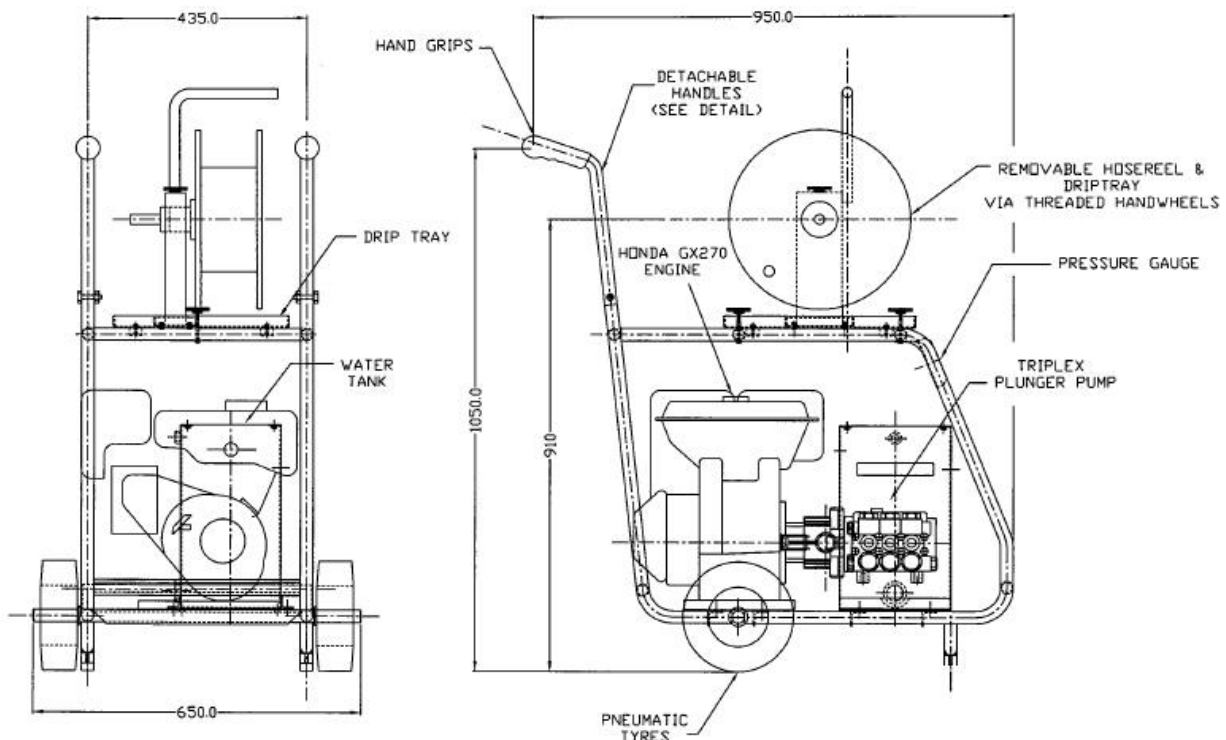

e: [sales@flowplant.com](mailto:sales@flowplant.com)  
 t: +44 (0)1722 325424  
 f: +44 (0)1722 411329

Gemini House, Brunel Road,  
 Churchfields Industrial Estate,  
 Salisbury, Wiltshire. SP2 7PU  
 United Kingdom