



High Pressure. Cleaner Solutions.

Technical Data Sheet



- **Standard kit included**
- **Hydraulic reel**
- **Drains up to 300mm diameter**

Model	Econopack
Pressure & Flow	2300 psi @ 18.8 gpm 2600 psi @ 16.4 gpm 3600 psi @ 13 gpm 4600 psi @ 10 gpm
Pump	Speck triplex plunger pump
Engine	Lombardini 48 hp water cooled diesel
Water Tank	Single – 90 gallons (390 litres) Twin – 180 gallons (780 litres)
Frame	Lightweight folded steel shot blasted and powder coated
Hose Reel	Variable-speed hydraulic-rewind hose reel with 100m high-pressure hose capacity, 90m hose included
Dimensions	1700mm Long X 1000mm Wide X 1450 mm High
Weight	Dry weight: From 740kg
Build Options	Hard Wire remote control

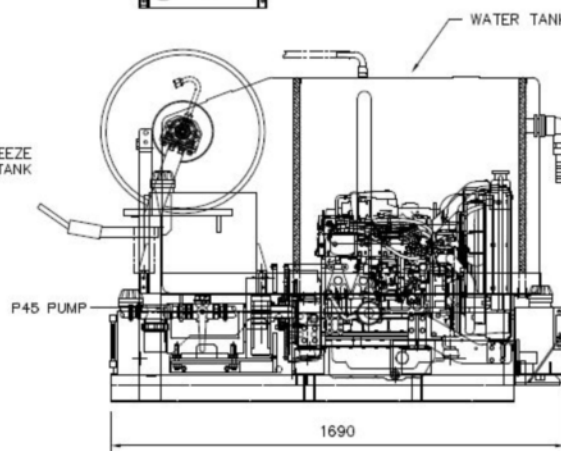
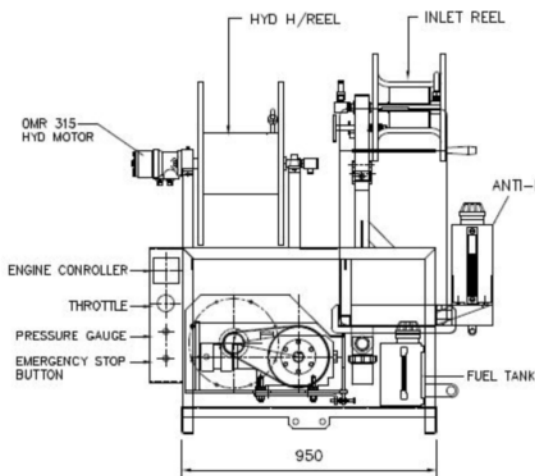
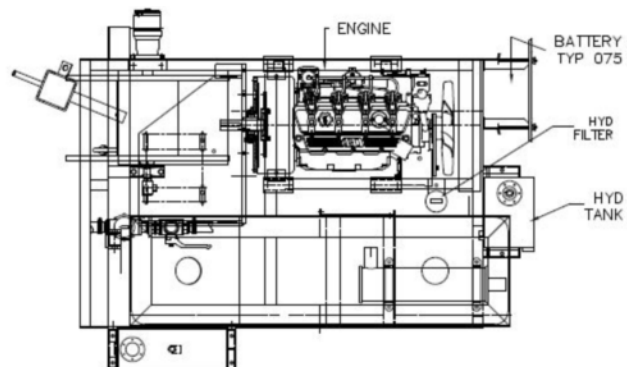

e: sales@flowplant.com
t: +44 (0)1722 325424
f: +44 (0)1722 411329

Gemini House, Brunel Road,
Churchfields Industrial Estate,
Salisbury, Wiltshire. SP2 7PU
United Kingdom